

OKS 424

High-Temperature Grease, synthetic

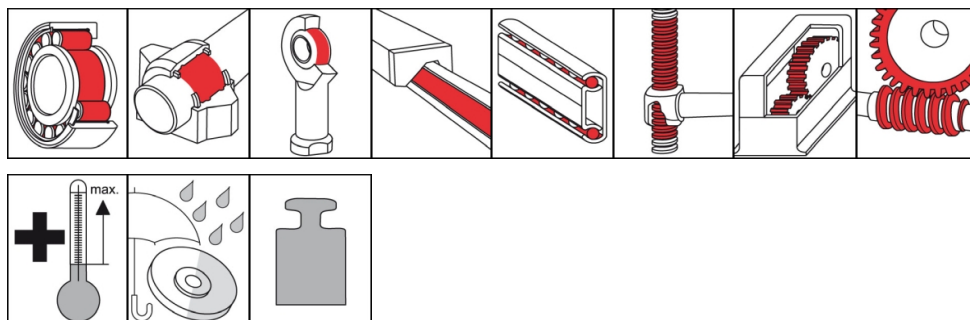

Description

Synthetic grease for bearing points subject to extremely high temperatures and corrosive environmental influences.

Applications

- Lubrication of rolling and friction bearings subjected to high temperatures, corrosive environmental influences
- Lubrication of bearing points at furnace, cooling-bed and conveyor systems, motors and hot-air fans that are subjected to temperature stress
- Suitable for lubricating exhaust-gas fans

Branches

- Plant and machine (tool) engineering
- Glass and foundry industry
- Rail vehicle technology
- Municipal services
- Paper and packaging industry
- Chemical industry
- Logistics
- Shipbuilding and marine technology
- Iron and steel industry
- Rubber and plastic processing

Advantages and benefits

- Reduces wear and friction
- Good corrosion protection
- Excellent temperature resistance
- When operating temperature is exceeded, forms only minimal residues
- Good plastic and elastomer compatibility
- Good resistance against water influence and aggressive environmental influences

Application tips

For optimum effect, carefully clean the lubricating point, for example with OKS 2610/OKS 2611 universal cleaner. Before filling for first time, remove anti-corrosion agent. Fill the bearing such that all functional surfaces are certain of being greased. Fill normal bearings up to about 1/3 of the free space inside the bearing. Low-speed bearings (DN value < 50,000) and their housings should be filled completely. The bearing and machine manufacturer's instructions should be observed. Subsequent lubrication at the lubrication nipples by grease gun or by automatic lubrication system. Assess the lubrication frequency and quantity on basis of service conditions. If old grease cannot be removed, restrict the quantity of grease so as to avoid overlubricating the bearing. If lubrication frequencies tend to be low, you should aim for a full grease change. Only mix with suitable lubricants.

Packaging

- 400 ml Cartridge
- 1 kg Can
- 5 kg Hobbock
- 25 kg Hobbock
- 180 kg Drum



KLÜBER
a product brand of LUBRICATION

OKS 424

High-Temperature Grease, synthetic

Technical data

	Standard	Conditions	Unit	Value
Main components				
base oil				polyalphaolefine
thickener				Polyurea
Application related technical data				
marking	DIN 51 502			KHC1-2S-40
Viscosity base oil	DIN 51 562-1	at 40°C	mm ² /s	400
Viscosity base oil	DIN 51 562-1	at 100°C	mm ² /s	40
drop point	DIN ISO 2176		°C	> 230
consistency	DIN 51 818	DIN ISO 2137	NLGI grade	1-2
worked penetration	DIN ISO 2137	60 double strokes	0.1 mm	280-310
lower operating temperature	DIN 51 805	≤ 1,400 hPa	°C	-30
upper operating temperature			°C	200
maximal operating temperature			°C	230
colour				beige
density	DIN EN ISO 3838	at 20°C	g/cm ³	0.85
water resistance	DIN 51 807-1	3h/90°C	Degree	0-90
DN value (dm x n)			mm/min	500,000
SKF-EMCOR	DIN 51 802		corr. degree	1

Klüber Lubrication München GmbH & Co. KG
Geisenhausenerstraße 7 / 81379 München /
Germany / phone +49 89 7876-0

The data in this document is based on our general experience and knowledge at the time of publication and is intended to give information of possible applications to a reader with technical experience. It constitutes neither an assurance of product properties nor does it release the user from the obligation of performing preliminary field tests with the product selected for a specific application. All data are guide values which depend on the lubricant's composition, the intended use and the application method. The technical values of lubricants change depending on the mechanical, dynamical, chemical and thermal loads, time and pressure. These changes may affect the function of a component. We recommend contacting us to discuss your specific application. If possible we will be pleased to provide a sample for testing on request. Klüber products are continually improved. Therefore, Klüber Lubrication reserves the right to change all the technical data in this document at any time without notice.